

DIMENSIONS

OPERATION:

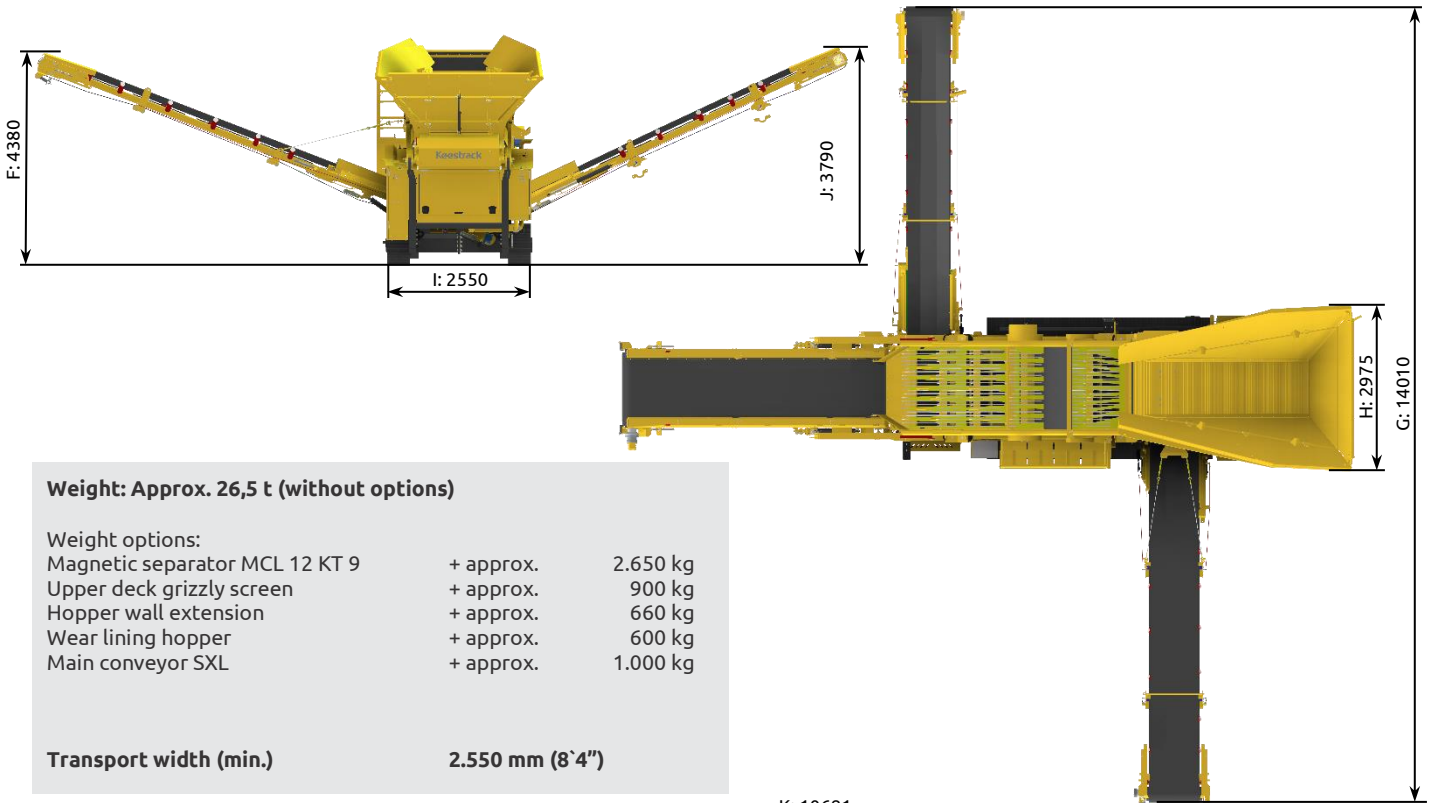
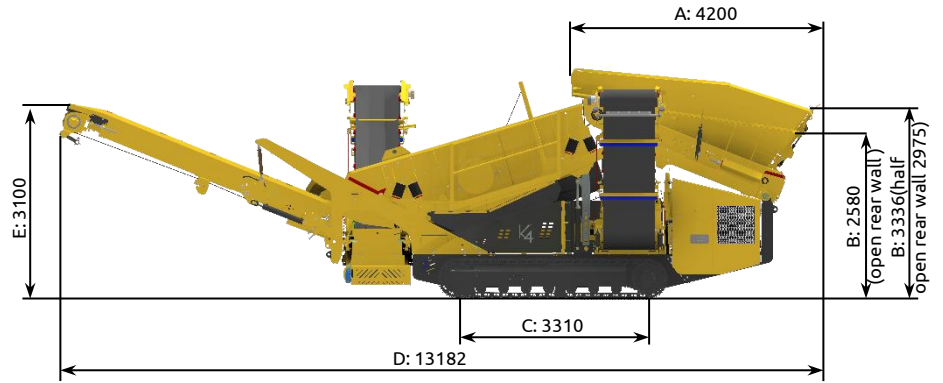

Weight: Approx. 26,5 t (without options)

Weight options:		
Magnetic separator MCL 12 KT 9	+ approx.	2.650 kg
Upper deck grizzly screen	+ approx.	900 kg
Hopper wall extension	+ approx.	660 kg
Wear lining hopper	+ approx.	600 kg
Main conveyor SXL	+ approx.	1.000 kg

Transport width (min.) 2.550 mm (8'4")

TRANSPORT:

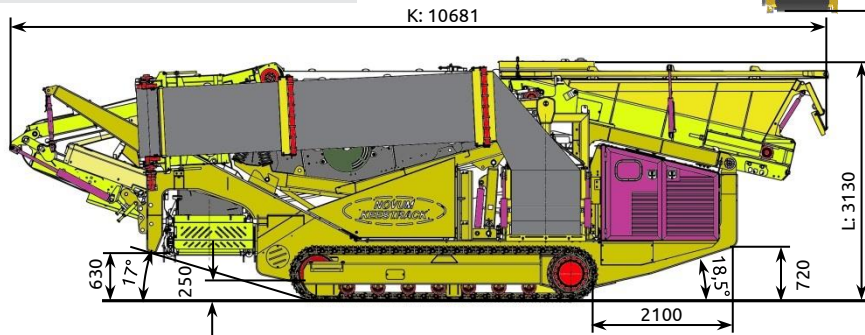

REMARK: All pictures might show options, not included in the scope of supply

A	B	C	D	E	F	G	H	I	J	K	L
4200	3336	3310	13182	3100	4380	14010	2975	2550	3790	10681	3130
13'9"	10'11"	10'10"	43'3"	10'2"	14'4"	46'0"	9'9"	8'4"	12'5"	35'0"	10'3"